

Wheel Chair Lift Interlock

The Intellitec Wheel Chair Lift Interlock is an electronic device designed to provide the interlock functions needed for wheel chair lifts on buses and other specialty vehicles.

The interlock prevents operation of the lift; unless ignition is on, the transmission is in park, the parking brake is set and the lift door is open. When all of these conditions are true, the interlock module activates the lift relay allowing the lift to be operated. The module also activates the vehicles shift lock mechanism whenever ignition is on and either the parking brake is set or the lift door is open.

Diagnostic lights and Bypass switch

In the event that the lift interlock is preventing the operation of the lift due to a faulty input switch, the module has 5 diagnostic LEDs that help the technician or operator determine the cause. The corresponding LED will light when the lift door is open, the transmission is in park, the park brake is set, ignition is on, or the emergency by pass has been activated. If any of these inputs is missing, the associated LED will not illuminate.

In the event that a fault is preventing the lift from being deployed or stowed, the operator may press the bypass push button located on the module to allow power to the lift. The bypass will remain active until ignition is turned off. When ignition is turned on again, the interlock will prevent operation of the lift if the proper conditions are not present. A diagnostic indicator light will turn on to indicate that the bypass is on.

P/N 00-00847-000 12VDC



131 Eisenhower Lane North
Lombard, IL 60148
630.268.0010 / 1.800.251.2408
FAX 630.916.7890

www.Intellitcsve.com

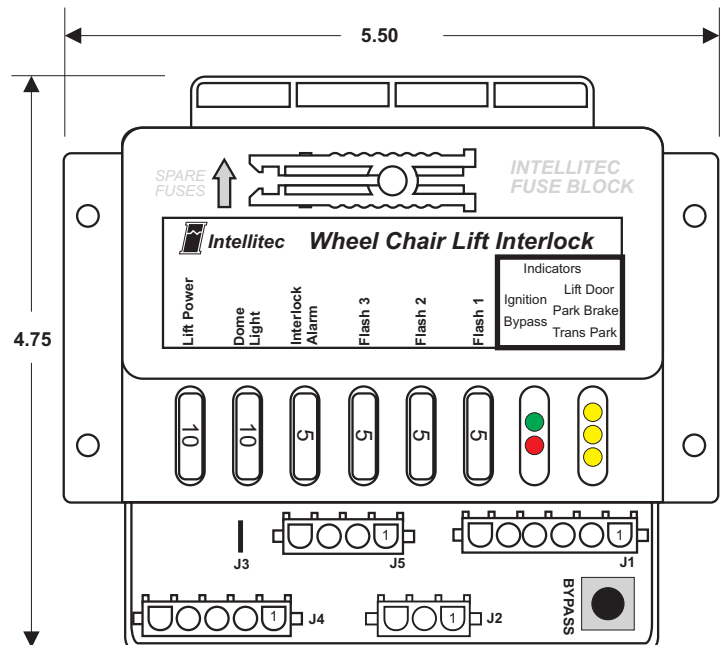

In addition to the interlock functions, the module provides for the following:

Lift Dome Light output, Fused 10A - Turns on when the lift door is open.

Interlock not satisfied output, Fused 5A - Turns on when ignition is on and the lift door is open but one or more of the other conditions is not present to allow operation of the lift. Can be used to operate a buzzer, a light or provide input to the Intellitec Message module. This output is a low side switch.

Flashing outputs, Fused 5A - These 3 outputs turn on and flash at a 0.3 second rate whenever the ignition is on and the park brake is set. Output 1 and 2 flash together, output 3 is on when outputs 1 and 2 are off. These outputs can be connected to a dash light, existing tail lights or additional warning lights on the rear of the vehicle.

P/N 53-00847-000 Rev. A 110102

Specialty Vehicle Electronics Group

Wheel Chair Lift Interlock

Connections:

J1-1 Shift lock output common
 J1-2 Shift lock output N/C
 J1-3 Shift lock output N/O
 J1-4 +12V input Lift door open
 J1-5 Ground input Lift door open
 J1-6 Ground input Park brake set



Only one connection required

J4-1 Lift door dome light output 10Amps
 J4-2 Low side lift power (Braun) remove lift power fuse No connection for (Ricon) high side
 J4-3 To lift power relay

J4-4 Input Ignition
 J4-5 Power Ground

J5-1 5Amp flashing light output 1
 J5-2 5Amp flashing light output 2
 J5-3 5Amp flashing light output (compliment of 1 and 2)
 J5-4 5Amp Output Interlock not satisfied alarm

J2-1 Ground input Transmission in Park, used when Ford trans park harness is not used.

J2-2 Connection for Ford Transpark harness

J2-3 Connection for Ford Transpark harness

Harness for connection to Ford chassis for trans park signal is available

J3 +12 Volt input (Size wire to carry all loads supplied by this module)

Mating connectors:

Amp Mate N Lok:

J2 3 Pin 1-480700-0

J5 4 Pin 640586-1

J4 5 Pin 1-480763-0

J1 6 Pin 640585-1

J3 .250 female tab terminal

Contacts:

For 14-18 AWG 350919-3

For 10-12 AWG 640310-3

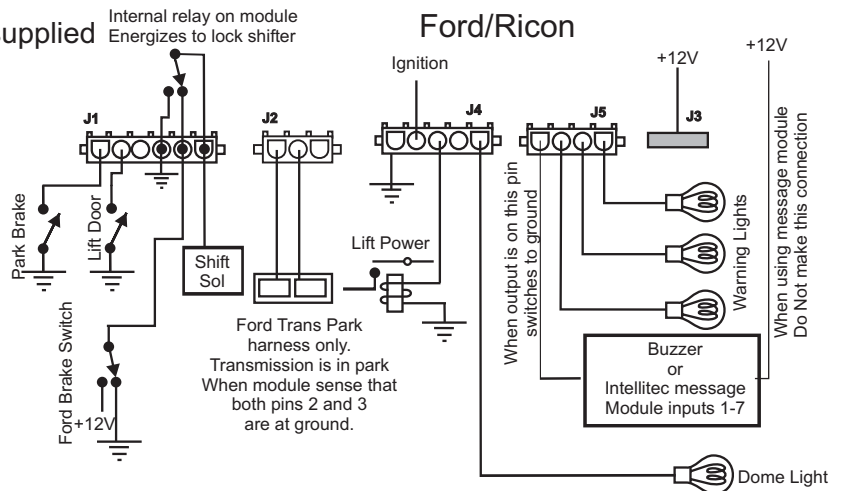

P/N 00-00847-000 12VDC

For other wiring configurations see Lift Interlock Installation Guide or Contact Intellitec.

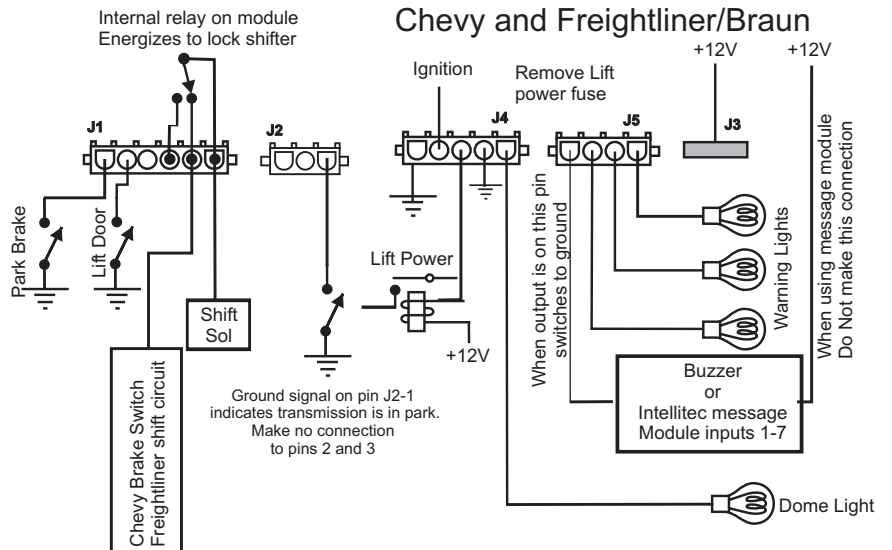

Intellitec

131 Eisenhower Lane North

Lombard, IL 60148

630.268.0010 / 1.800.251.2408

FAX 630.916.7890

P/N 53-00847-000 Rev. A 110102