

PMC I/O Modules 320 and 330, are members of Intellitec's Programmable Multiplex Control family. They work in combination with the PMC CPU and other standard, semi-custom or custom I/O modules, allowing you to create the exact system configuration that you want, from basic to all encompassing.

There are ten connections for low wattage loads, such as dash warnings lights, or beepers. The PMC CPU utilizes input information from other modules on the system, and via the PMC communications link, controls the ten loads of this module. All of the output harnesses are connected with AMP Mate-N-Lok connectors to reduce installation time and errors.

All loads are negative (low-side) switched to a local load ground which needs to be provided to the module. In other words, the outputs are connected between the load and ground. (This is different than the 406/416 module which provides for high-side switching.) A fused load power connection is available at the module which can be used for loads requiring a power source.

The approximate module dimensions are 6.375" X 3.750" X 1.875" (16.2mm X 9.5mm X 4.8mm). It should be installed in a protected environment inside of the vehicle.

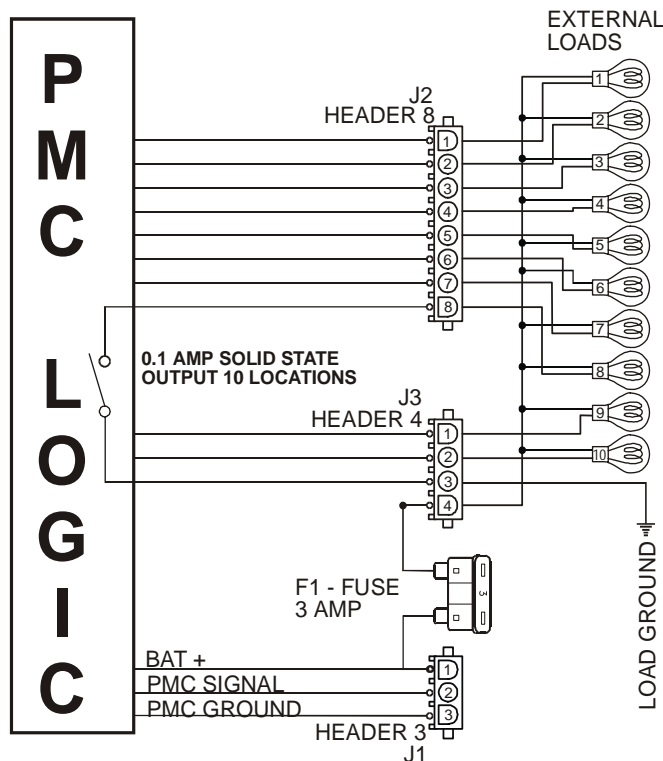
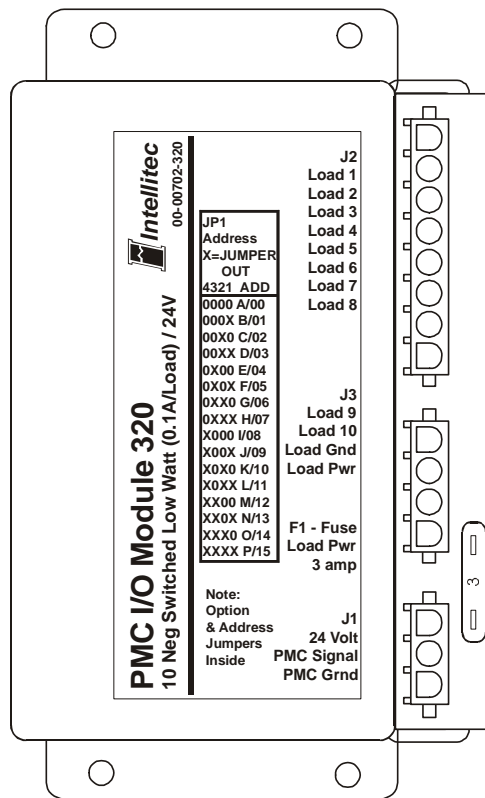

### Specifications:

#### General Connections

		00-00702-330	00-00702-320
Nominal Vehicle Voltage		12V	24V
J3 - 4	Fuse 1, Load Power	3 Amps Max.	3 Amps Max.
J3 - 3	Local Load Ground		
J1 - 1	External Power from CPU	5 Amps Max.	5 Amps Max.
J1 - 2	PMC Signal	18 awg Min.	18 awg Min.
J1 - 3	PMC Ground	18 awg Min.	18 awg Min.

#### Channel Designations

Channel	Connection	Type	Name	Rating *
1	J2 -1	Output, Negative Switch to Gnd	Load 1	0.1 Amp
2	J2 -2	Output, Negative Switch to Gnd	Load 2	0.1 Amp
3	J2 -3	Output, Negative Switch to Gnd	Load 3	0.1 Amp
4	J2 -4	Output, Negative Switch to Gnd	Load 4	0.1 Amp
5	J2 -5	Output, Negative Switch to Gnd	Load 5	0.1 Amp
6	J2 -6	Output, Negative Switch to Gnd	Load 6	0.1 Amp
7	J2 -7	Output, Negative Switch to Gnd	Load 7	0.1 Amp
8	J2 -8	Output, Negative Switch to Gnd	Load 8	0.1 Amp
9	J3 -1	Output, Negative Switch to Gnd	Load 9	0.1 Amp
10	J3 -2	Output, Negative Switch to Gnd	Load 10	0.1 Amp

#### Mating Connections

Designator	Function	Connector	Mating Part #	Contact, Typical
J1	PMC Link	3 Pin Amp Mate-N-Lok	14-18 AWG 1-480700-0	10-12 AWG 350919-3, 640310-3
J2	Loads	8 Pin Amp Mate-N-Lok	1-480702-0	350919-3, 640310-3
J3	Loads, Power, Gnd	4 Pin Amp Mate-N-Lok	640586-1	350919-3, 640310-3

	Jumpers		Module	
	4	3 2 1	Address	Address
Module can be set for 1 of 16 address. Set four jumpers on jumper block JP2 per table to the right. X = Jumper is out.	0 0 0 0		A	X 0 0 0 I
	0 0 0 X		B	X 0 0 X J
	0 0 X 0		C	X 0 X 0 K
	0 0 X X		D	X 0 X X L
	0 X 0 0		E	X X 0 0 M
	0 X 0 X		F	X X 0 X N
	0 X X 0		G	X X X 0 O
	0 X X X		H	X X X X P

\* **Note:** Heavier loads can be connected to this module if the following guidelines are observed. Any single Load shall not exceed 0.5 amps, and neither the sum of the currents in Loads 1-5, nor the sum of the currents in Loads 6-10 shall exceed 0.5 amps. (Example1: Load1=0.25 amps, Load2=0.05 amps, Load3=0.1 amps, Load4=0.1amps, Load5=No connection, Load1-5 sum =0.5 amps is an acceptable configuration. Example 2: Load6=0.5 amps, Load7=No connection, Load8=No connection, Load9=No connection, Load10=No connection, Load 6-10 sum =0.5 amps is an acceptable configuration.)